

W.L.L	Wymiary											Min. promień skretu	Teoretycznie minimalna siła wymagana do uruchomienia wozka	Waga	
														Wozek przepychany	Wozek napędzany łańcuchem
t	mm											mm	N	kg	
	a	b	c	d	e	f	g	h	i	j	F				
0,25	22	22	220	175	11	50	74	7	12	-	45 - 152	650	-	3,5	-
0,5	27	25	324	225	15	62	88	16	16	-	50 - 220 220 - 300	900	55	8,5	-
1	30	30	334	252	15	62	103	17	17	100	58 - 220 220 - 300	1000	55	10,5	19
2	38	40	342	300	18	80	127	18	21	120	66 - 220 220 - 300	1200	100	18	22,5
3	45	48	358	360	15	97	177	18	21	135	74 - 220 220 - 300	1300	75	32	37,5
5	52	58	372	400	20	110	192	23	21	145	90 - 220 220 - 300	1400	120	48,5	55

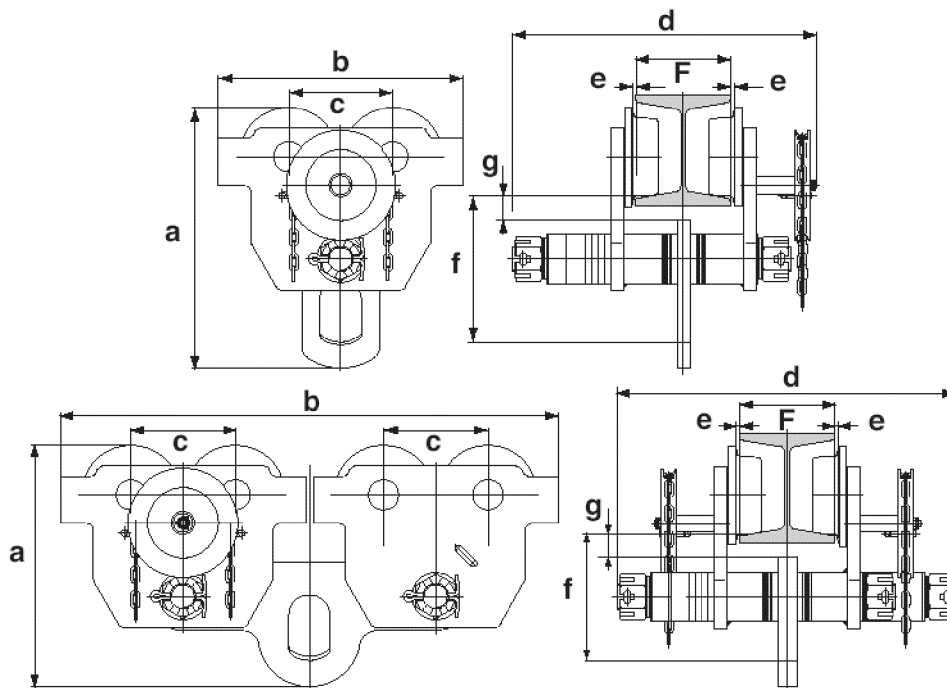

	W.L.L	Wymiary								Min. promień skretu	Teoretycznie minimalna siła wymagana do uruchomienia wozka	Waga
		t	mm									
		a	b	c	d	e	f	g	F			
Wozek przepychany	10	500	470	200	550	2,5	280	45	125 - 320	2500	-	105
	10	500	470	200	583	2,5	280	45	125 - 320	2500	34	115
Wozek napędzany łańcuchem	20	500	955	200	654	2,5	270	45	136 - 320	5000	68	254